



## Description:

Mining diesel suspension manipulator type DMZ50F is separate hydraulic aggregate, which is used as a traction vehicle, dedicated for transport of sets on the monorail suspension way with profile I155 in horizontal plane and in max. dip  $\pm 30^\circ$  (modification DMZ50F-1 and DMZ50F-2).

As and hydraulic aggregate is possible to use it for feeding of the small mechanization (for example bolt drilling machine VPS01, sludge pump S3TDI, pulse tightener HPU2501P, hand bush hammer LH11 etc.). There is a possible modification to the diesel hydraulic manipulator, as it may be used without drive (DMZ50F-0), this modification is not to be used on the suspended monorail line, however it works as a stationary hydraulic source. To the manipulator can be added equipment for transport of materials, for example transport hydraulic equipment NZH2/4 and cabin for transport of material.

It can be used on the any mining place on the monorail with the compliance of the valid safety regulations and enactment of the Direction of use of manipulator and monorail.

Mining diesel manipulator DMZ50F can be used in surrounding with the danger of explosion of methane and dust coal to the SNM 2 degree, by the § 232 Regulations of CMI No. 22/1989 digest as amended by the prescripts. According to the Government statute No.1 NV 23/2003 (direction of the European parliament and Council EU 94/9/ES) the equipment is included in group I and category M2. Manipulator satisfies to NV 176/2008 (direction of the European parliament and Council EU 2006/42/ES).

**Technical parameters:**

Type mark:	<b>DMZ50F</b>		
Modification:	DMZ50F-0	DMZ50F-1	DMZ50F-2
Engine:	A2300		
Number of cylinders:	4		
Max. engine operating:	36 kW		
Number of driving units:	0	1	2
Max. traction:	---	20 kN ± 10%	40 kN ± 10%
Weight:	1785 kg	2345 kg	2735 kg
Max. speed.:	---	3,2 km/h	3 km/h
Operating pressure:	25 MPa		
Pressure of the safety-valve:	28 MPa		
Max. operating pressure:	35 MPa		
Monorail:	---	profile I155	profile I155
Radii of the curves:			
- horizontally	---	4 m	4 m
- vertically	---	8 m	8 m
Max. dip of monorail:	---	30°	30°
Proportions of the manipulator:			
- Totally length	2560 mm	2560 mm	3158 mm
- Totally height	1086,5 mm	1277 mm	1277 mm
- Height to the rail	---	1141 mm	1141 mm
- Totally width	1000 mm	915 mm	915 mm

**Dimensional drawing:**

DMZ50F-0 (without drive)

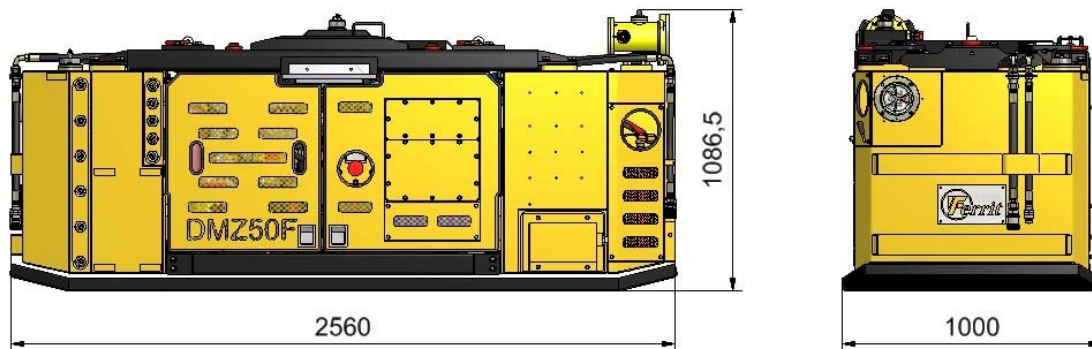

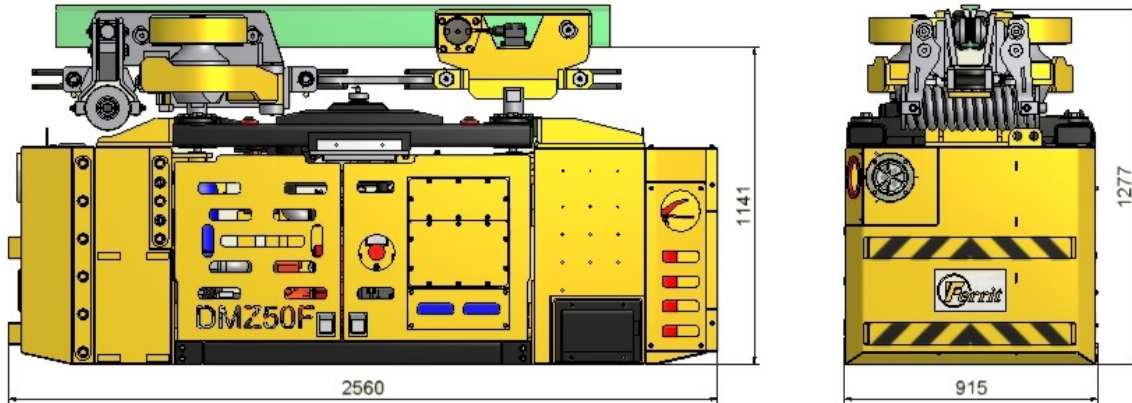
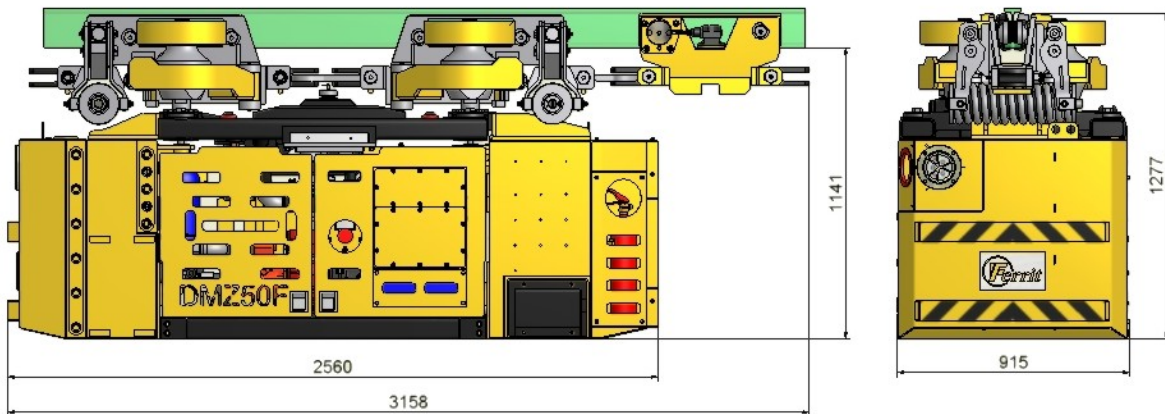
*DMZ50F-1 (with one drive)*

*DMZ50F -2 ( with two drives)*

### Ordering:

In the order please notice type of the equipment, you ask for, supply number by thereafter ordering key, number of pieces, specific requirements (documentation in electronic form) and number sets of the accompanying documentations (Direction for use, Catalogue of spare parts – usually we enclose 2 sets of this documentation)

### Ordering key:

TYPE - MODIFICATION	NUMBER OF DRIVES	SUPPLY NUMBER
DMZ50F-0	0	653-00-00000-9-44
DMZ50F-1	1	653-00-00000-9-04
DMZ50F-2	2	653-00-00000-9-24



**MINING DIESEL  
SUSPENSION MANIPULATOR  
DMZ50F**

**KL-DMZ50F-EN**

Version	Valid from
1	22.7.2010

Page 4/4

**Example of ordering:**

An order of 1 piece of mining diesel suspension manipulator type DMZ50F with one drive and delivery of 3 sets of accompanying documents.

MACHINE TYPE	SUPPLY NUMBER	NUMBER OF PCS.	ACCOMPANYING DOCUMENTATION	SPECIFIC REQUIREMENTS
DMZ50F-1	653-00-00000-9-04	1	3 SETS	

**Delivery date:** 18 weeks from confirmation the definite order

**Customs classification:** 8602 90 00 00



FERRIT s.r.o, Na Zbytkách 41 , Staré Město u Frýdku-Místku,  
739 01 pošta Baška, Czech Republic  
Tel. +420 / 558 411 605, fax +420 / 558 411 620  
E-mail: [ferrit@ferrit.cz](mailto:ferrit@ferrit.cz), [www.ferrit.cz](http://www.ferrit.cz)