



Description:

Hydraulic distributor of type NEV24V ... serves as hydraulic component for closing or redirecting flow of hydraulic liquid in hydraulic systems of mining machines. In explosive operating magnet of distributor is fed by direct or a.c. voltage from electric circuit of mining machine.

Hydraulic distributor of type NEV24V ... is determined to work in underground of mines with explosion hazard of methane and with occurrence of inflammable gas. According to regulation of direction EC No.94/9 ATEX operating magnet of distributor belongs to group of machines I, category M2 and in the case of the occurrence of explosive atmosphere it has to be switched off.

Operating magnet of hydraulic distributor of type NEV24VE is electric equipment, magnet in explosive firm shutter. It consists of box of magnet, coil with winding, bushing, connecting lead and sealing compound and magnet core. Coil along with connecting lead are hosed in the box of magnet by authorized sealing compound. By it is ensured in explosive implementation of magnet.

Operating in explosive magnet of hydraulic distributor of type NEV24VE ... is magnet which is fed from electric system of mining machine. Magnet serves to (if it is alive) transposition of slider of hydraulic distributor thereby to redirecting or closing the flow of hydraulic liquid. After fade away of supply voltage of magnet the slider of hydraulic distributor is rebuilt by spring into the basic location.

Operating in explosive magnet of hydraulic distributor of type NEV24VE ... is fed by direct or a.c. voltage 24 V electric system of mining machine. Maximum current of magnet is 500 mA. In explosive magnet has to be protected against over freight and against short circuit by fuse, which is a part of electric system of mining machine.

Warning: If the hydraulic distributor is invested by two magnets, the supply circuit has to eliminate the possibility of simultaneous feeding of both magnets.

Technical parameters:

Voltage rating	24 V, DC, IT or 24 V, AC, IT (according to used, isolated from skeleton coil of electromagnet)
Rated current	500 mA
Rated power	11 W
Weight with one magnet	2,2 kg
Weight with two magnets	3,4 kg
Degree of covering according to ČSN EN 60529	IP54
Kind of in explosive performance	I M2 Ex d I
Sealing liquid	mineral oil
Purview of operating viscosity	20 - 400 mm ² .s ⁻¹
Maximum pressure in hydraulic network	25 MPa
Maximum flow of hydraulic liquid	80 dm ³ .min ⁻¹
Connecting measures	ISO 4401-AB-03-4-A
Purview of operating temperature of liquid	-25°C – 70°C
Purview of operating temperature of surroundings	-25°C – 50°C

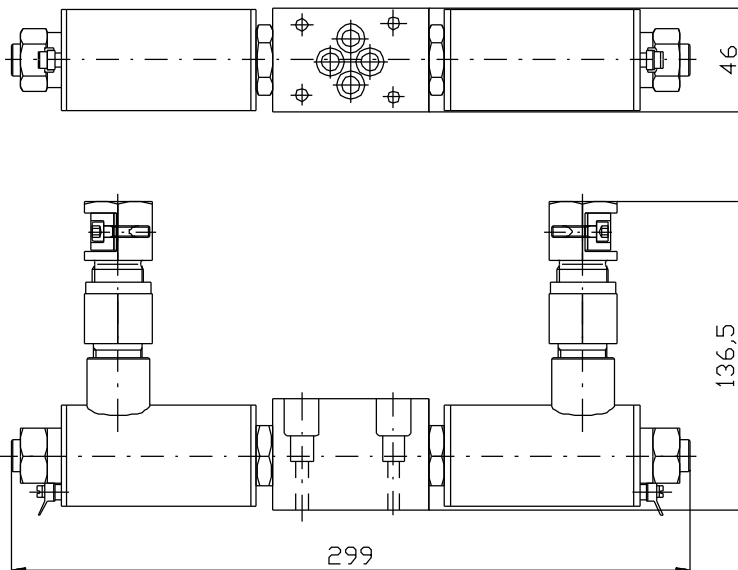
Certificate ATEX : KDB 04 ATEX 128X
Dimensional drawings:
Hydraulic distributor NEV24VC

Hydraulic distributor NEV24VE

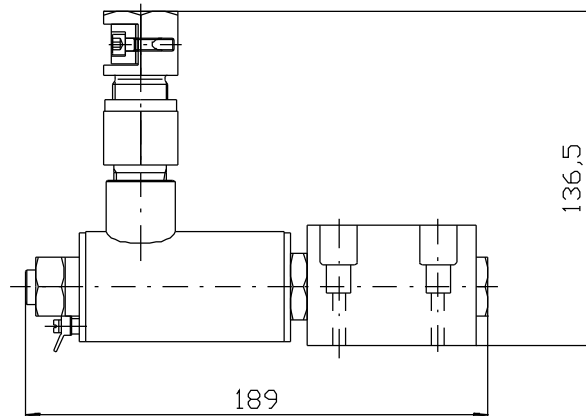
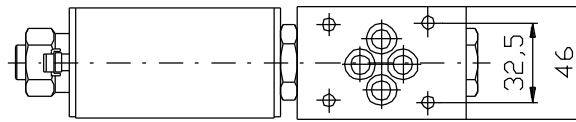



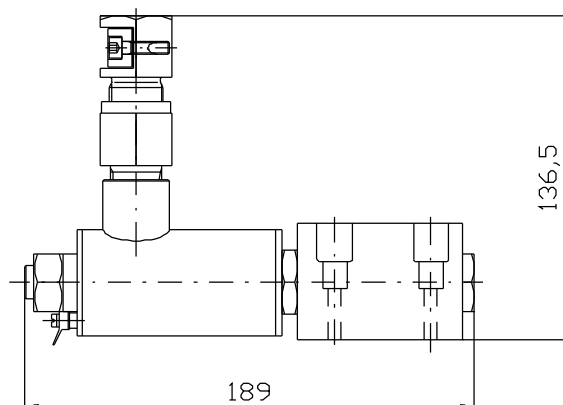
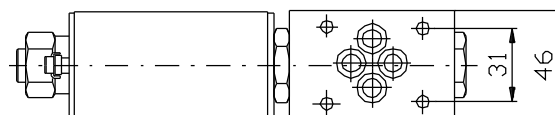



Hydraulic distributor NEV24VF

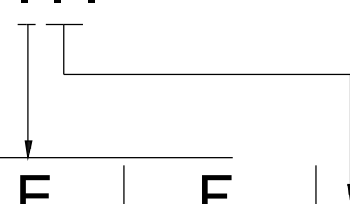

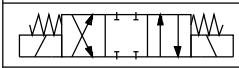
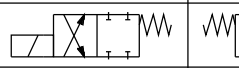
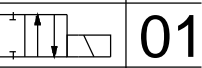
Type of key:

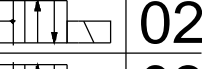
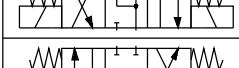
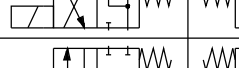
NEV24V . . .

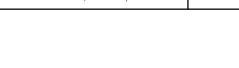
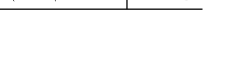

C	E	F	
			01
			02
			03
			04
			16

Ordering:

In the order please state the type of the machinery you ask for, supply number, number of units, number of asked sets accompanying documentation (Direction for use, Catalogue ND, etc. – usually we enclose 2 sets of this documentation) and specific requirements (for example different paint, etc.)

Warning:

Is necessary to name what voltage spool of electromagnet will be cordless (equable DC or alternating AC) in the order in the specific requirements.



HYDRAULIC DISTRIBUTOR NEV24V...

KL-NEV24V-EN

Version	Valid from
1	4.4.2011

Page 5/5

Ordering key:

SUPPLY NUMBER	TYPE DESIGNATION
LZN05500.01	NEV24VC01
LZN05500.02	NEV24VC02
LZN05500.03	NEV24VC03
LZN05500.04	NEV24VC04
LZN05300.01	NEV24VE01
LZN05300.02	NEV24VE02
LZN05300.03	NEV24VE03
LZN05300.04	NEV24VE04
LZN05300.16	NEV24VE16
LZN09400.01	NEV24VF01
LZN09400.02	NEV24VF02
LZN09400.03	NEV24VF03
LZN09400.04	NEV24VF04
LZN09400.16	NEV24VF16

Example of ordering:

An order of one hydraulic distributor NEV24VE02 with a delivery 3 sets of accompanying document.

MACHINE TYPE	SUPPLY NUMBER	ITEMS NUMBER	ACCOMPANYING DOCUMENTATION	SPECIFIC REQUIREMENTS
NEV24VE02	LZN05300.02	1	3 SETS	

Delivery date: 14 weeks from confirmation the definite order

Customs classification: 8481 80 99 90



FERRIT s.r.o, Na Zbytkách 41 , Staré Město u Frýdku-Místku,
739 01 pošta Baška, Czech Republic
Tel. +420 / 558 411 605, fax +420 / 558 411 620
E-mail: ferrit@ferrit.cz, www.ferrit.cz